

LUXUL®

Innovation at every level



CATALOG 2023

LUVUL®

Innovation at every level

LUVUL is a brand specialized in crafting premium-grade kitchen sinks and accessories that are meticulously designed to exceed the highest quality standards prevalent in the market. We use the most advanced technology and the best materials to create products that are not only functional but also beautiful and built to last. From our rigorous testing process to our comprehensive quality control measures, we ensure that every product that leaves our factory meets our exacting standards.

At LUVUL, we understand that your kitchen is the heart of your home. That's why we've designed a range of products that not only look great but also make your life easier. Our sinks are designed to make preparing food, washing dishes, and cleaning up a breeze. We are constantly exploring every avenue of creative design to make practical elements beautiful.

Our commitment to innovation means that we are always pushing the boundaries of what is possible. We are constantly looking for new ways to improve our products and make them even better for our customers.

At our company, we deliver outstanding customer service and support. Our team of proficient professionals is readily available to address any queries you may have and to guide you in discovering the ideal product for your home.

We invite you to join our community and experience the LUVUL difference for yourself.







SPEEDY DRAIN

The first thing you notice is the striking visual aesthetic of the LUVUL sink. Its drainage system, featuring innovative drain lines and a sloped bottom, enhances both cleaning and drainage capabilities to a significant extent.



Flat bottom sinks often fall short of effectively draining water and debris. As a result, water often pools in the Sink, taking longer to dry and leading to the buildup of unsightly grime and food debris. Even basic food scraps like bread crumbs or fruit peels can become lodged in the corners of the sink, requiring significant time and effort to clean thoroughly.

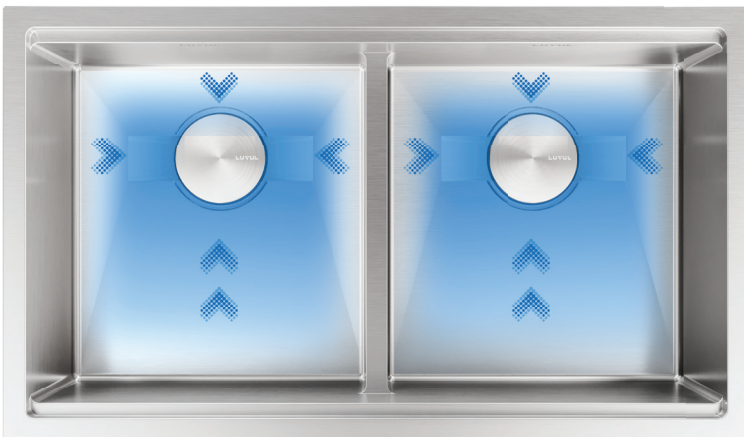

OTHER BRANDS

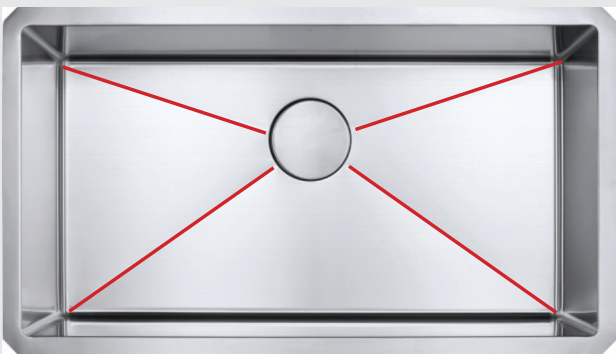

FLAT BOTTOM

LUVUL

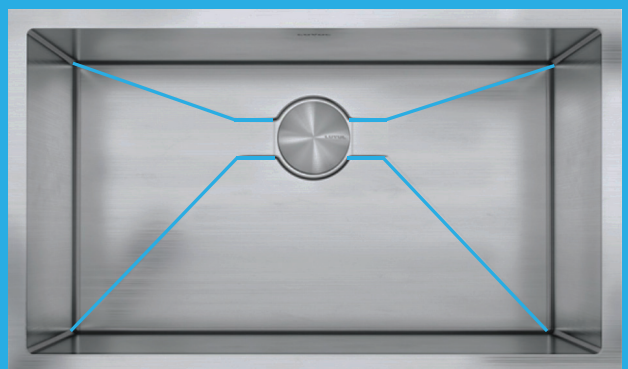

SLOPE BOTTOM

EXPERIENCE THE HIGHEST LEVEL OF SOUND INSULATION AND THERMAL EFFICIENCY

Most people are familiar with the excessive noise and vibration created by most sinks when using the garbage disposal. Over 90% of the surface area of the LUVUL sink is covered by an ultra-thick, professional-grade automotive insulation pad. The material is made from a non-toxic, odorless, waterproof, flame resistant, not VOC, rubber, and aluminum foil. It is generally accepted as the highest-quality solution for sound absorption in vehicles. This translates to more soundproofing than any other brand in the market, making LUVUL sinks the absolute quietest in the world.

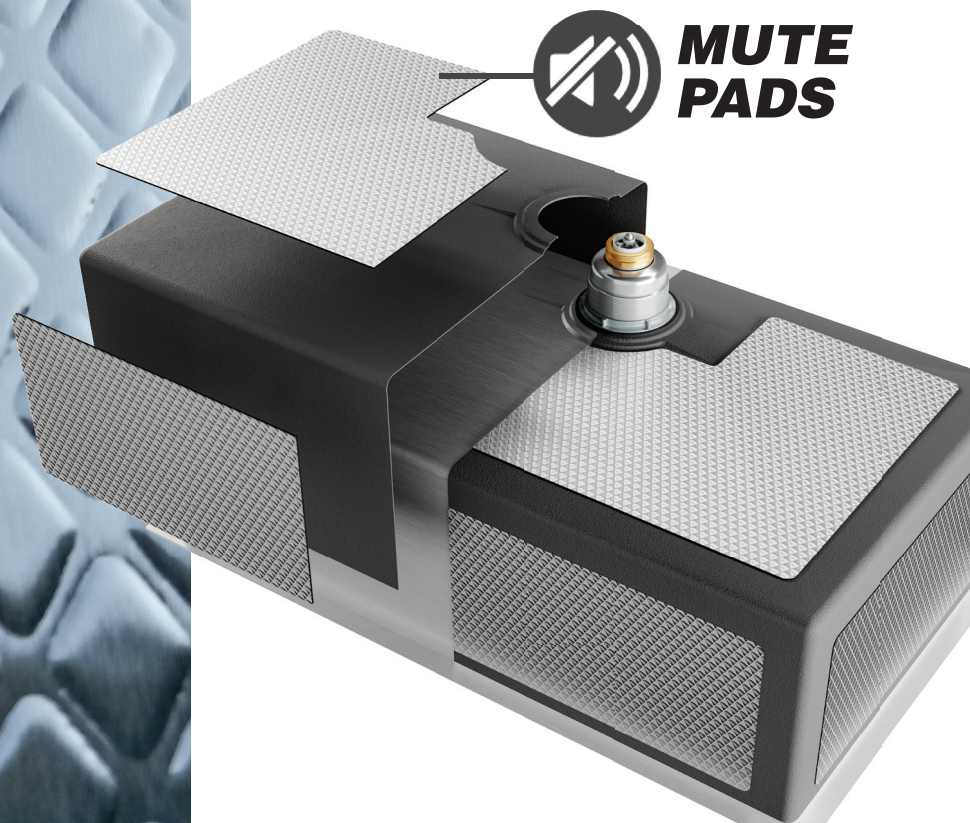
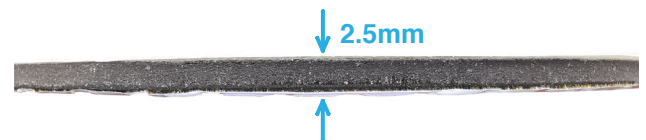

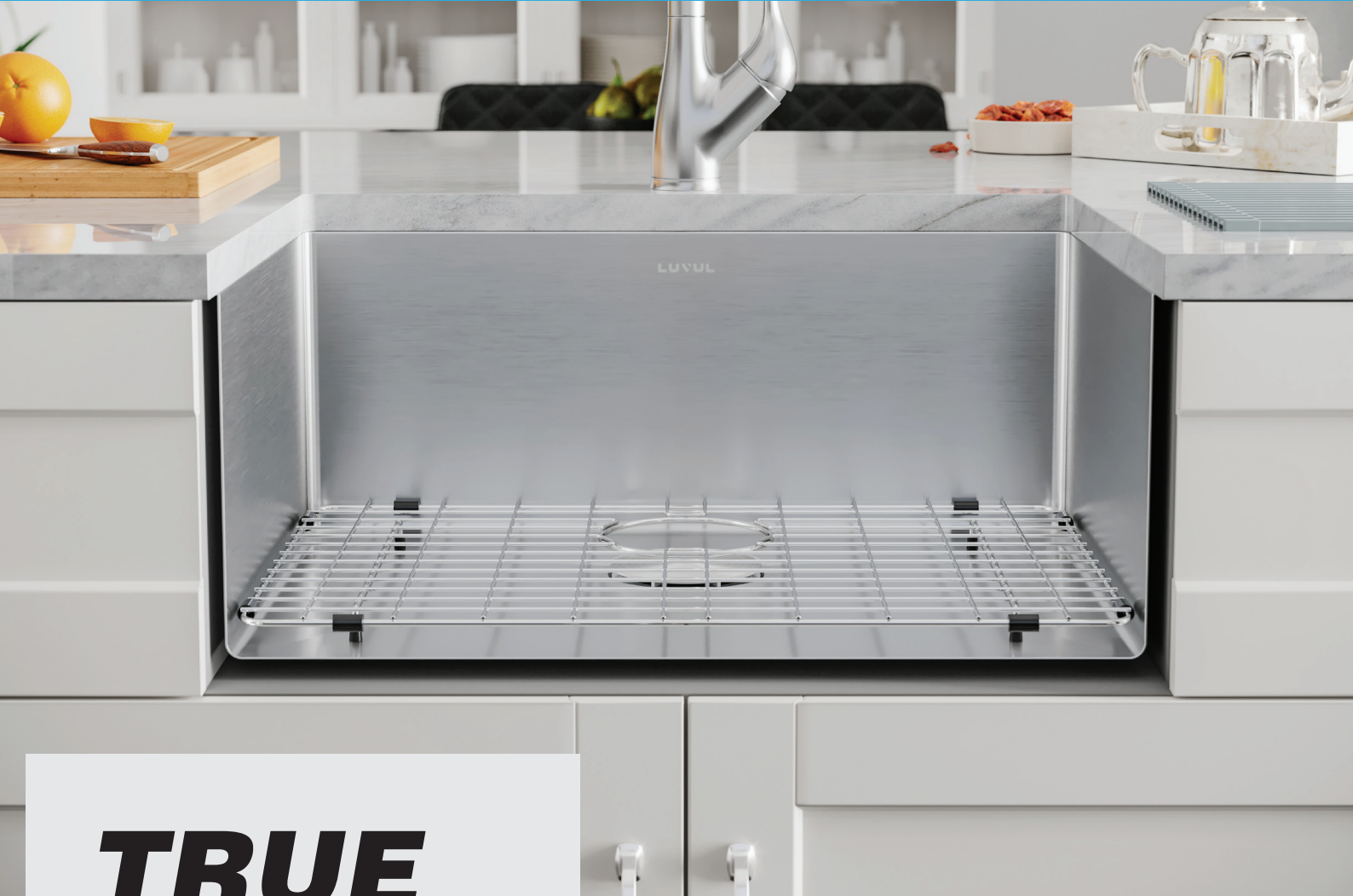

TRUE SIZE

At LUVUL, we have taken a customer-centric approach in the design of our sinks. While some sinks in the market feature an incline that allows for stacking and maximizing capacity during transportation, this design can result in different sizes at the top and bottom, which can limit the number of items that can fit inside the sink. In contrast, our sinks have a uniform size from top to bottom, which maximizes their internal capacity and allows for greater versatility in use. This design choice reflects our commitment to delivering the best products to our customers and ensuring that our sinks meet their varied needs and requirements.

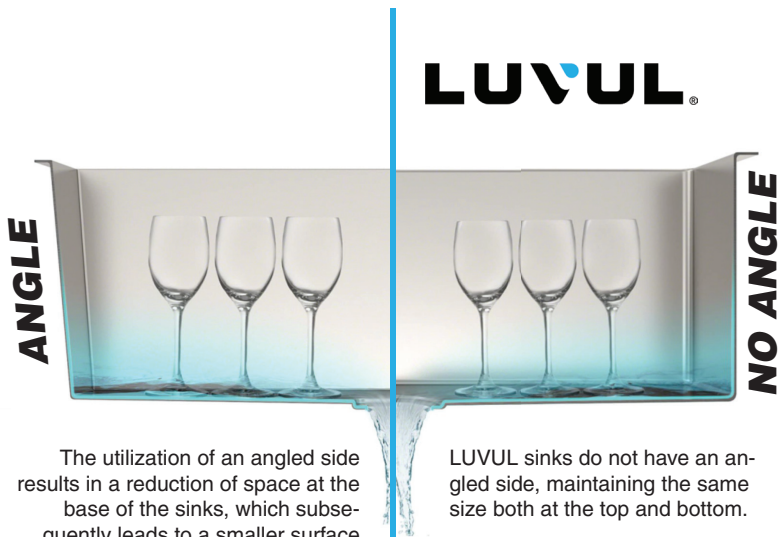

The utilization of an angled side results in a reduction of space at the base of the sinks, which subsequently leads to a smaller surface area and reduced storage capacity.

LUVUL sinks do not have an angled side, maintaining the same size both at the top and bottom.

16G

304 Stainless Steel

True 1.5mm 16 Gauge Stainless Steel material makes caring for your kitchen sink effortless and hassle-free.

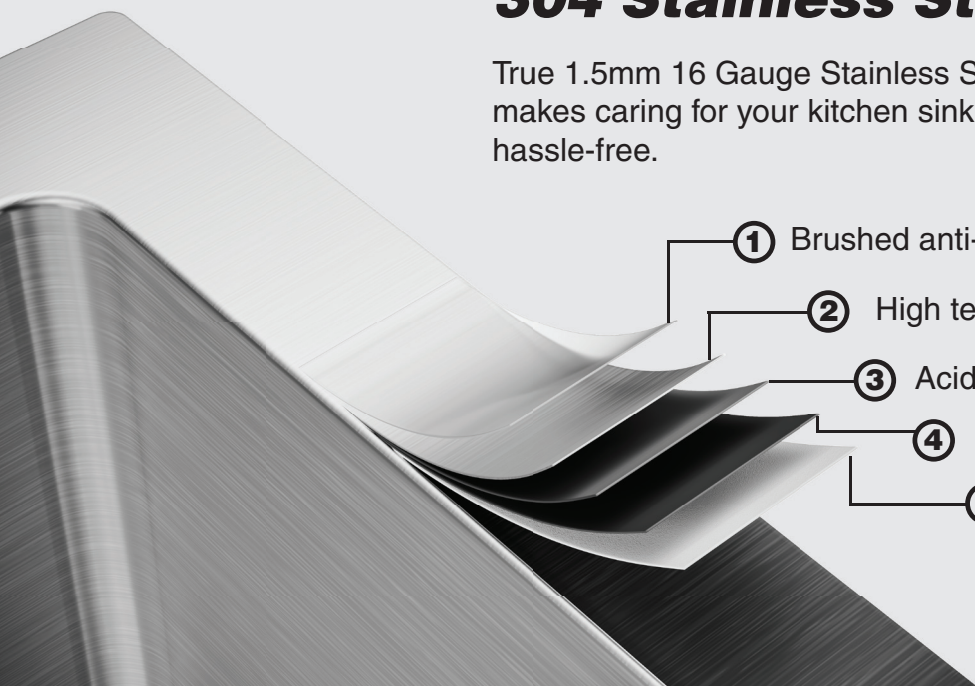

- ① Brushed anti-corrosion layer
- ② High temperature anti-corrosion layer
- ③ Acid-base anti-rust layer
- ④ High temperature degreasing layer
- ⑤ 304 polished stainless steel

R10 **CORNERS**

Say goodbye to hard-to-reach corners and endless scrubbing with our sleek, gently curved R10 radius corner sinks that are a breeze to keep clean.

Hard-wearing **SATIN** **FINISH**

Our products are designed to withstand even the toughest stains from coffee, wine, and grease.

Exceptional resistance to dirt and grime, allowing you to maintain your kitchen spotless.

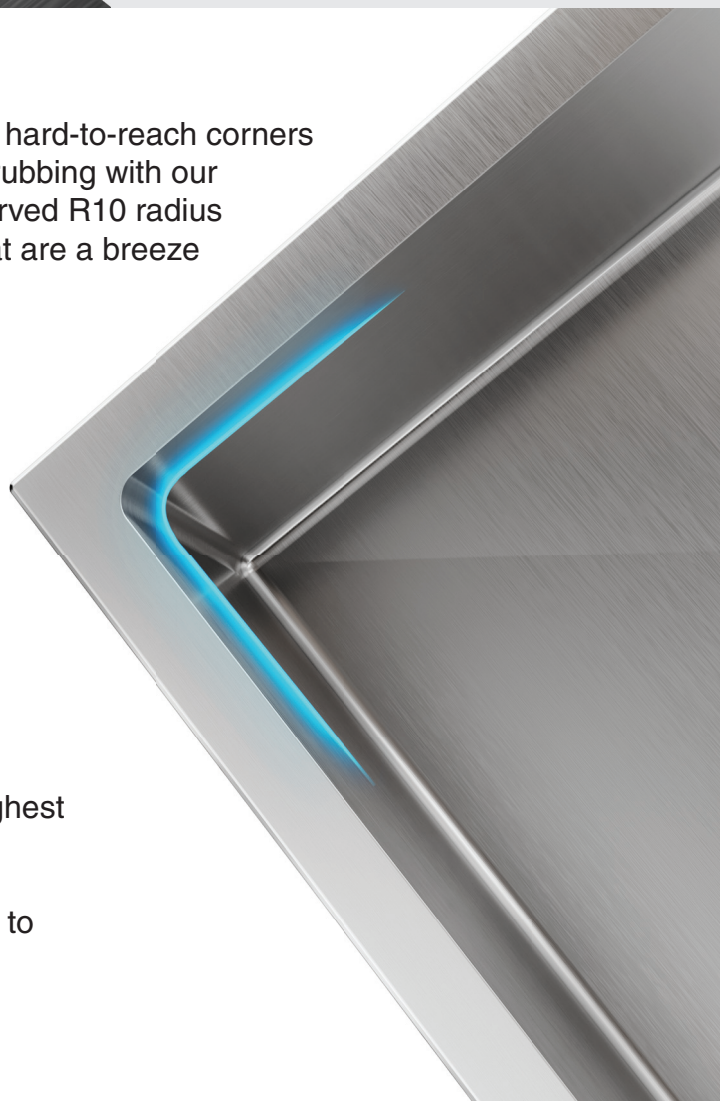

BASKET STRAINER AND LID

We are proud to introduce our 3-1 Basket Strainer & Lid - a strainer that exemplifies exceptional attention to detail and construction quality.

The strainer is crafted from 100% stainless steel, ensuring longevity and durability. Additionally, the strainer is outfitted with two rubber gaskets, which are significantly thicker than any others available in the market, enabling a secure and leak-free installation with virtually no risk of unwanted leaks.

The deep, removable basket included with the strainer effectively prevents debris from clogging your drainpipes, simplifying the maintenance process. The basket also possesses the unique ability to control water flow, enabling you to conveniently stop and release water as needed.

Furthermore, the strainer is not only designed for functionality, but also aesthetics. The beautiful decorative lid adds a touch of modern sophistication to any sink.

Overall, this strainer is a testament to our commitment to delivering high-quality plumbing products that exceed expectations. With its practical design and exceptional construction quality, it is a perfect addition to any space.

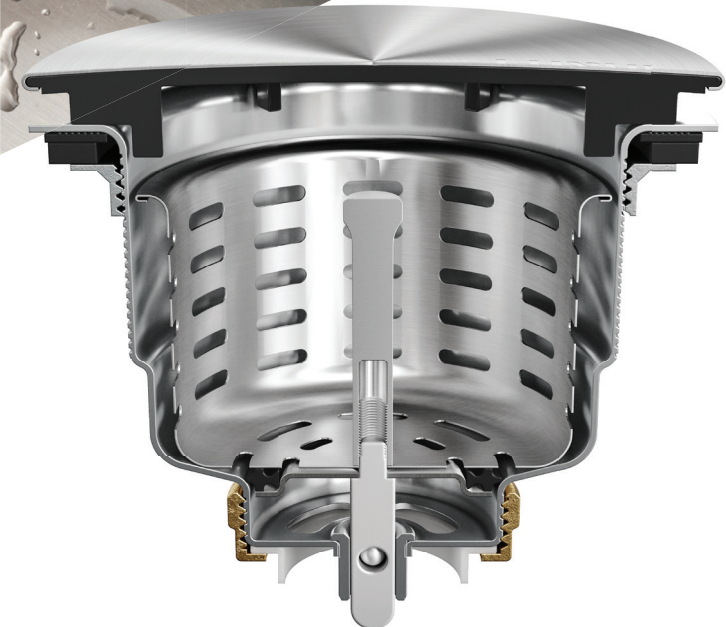

100% 304 Stainless Steel

DUAL HEIGHT GRIDS

Deep sinks are popular among consumers, and all LUVUL sinks are 10 inches deep. However, we understand that some customers prefer shallower sinks. So, LUVUL has devised another innovative solution by including grids that reduce the depth of the sink by 3 inches. By installing the included 3 inch long rubber feet, customers can customize the depth of their sink to their liking and enjoy a more comfortable and convenient experience. Just replace the standard grid feet with the 3 inch rubber feet, and, just like that, you have a 7 inch deep sink. We strive to provide our customers with the best possible products and solutions to meet their needs, and these new bottom grid feet are just one example of our commitment to excellence.



9/16"
15mm

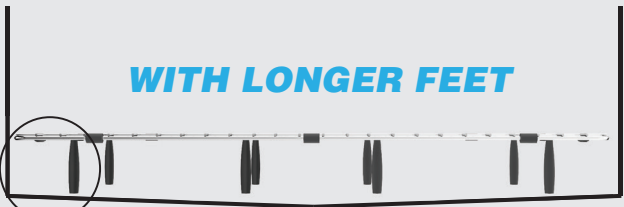

3-3/8"
85.7mm





LUVUL[®]
Innovation at every level

LUVUL
© 2023 LUVUL, All rights reserved.
luvul.com
@luvulkb